

Sanitana

CARACTERÍSTICAS DO MODELO:

- MATERIAL: LATÃO (ACABAMENTO: CROMADO)
- LATÃO (ACABAMENTO: PRETO)
- PROFUNDIDADE DE INSTALAÇÃO 55 A 85 mm
- GARANTIA: 5 ANOS
- PESO: 2.00 KG

PEÇA:

- DESCRIÇÃO: TORNEIRA DE ENCASTRAR 4 VIAS
- SERIE: UNIC
- VERSÃO: TERMOSTÁTICA ESPELHO RECTANGULAR
- REF: S50005969950706 / S50005969971606

CROQUIS COM DIMENSÕES GERAIS E DE LIGAÇÃO:

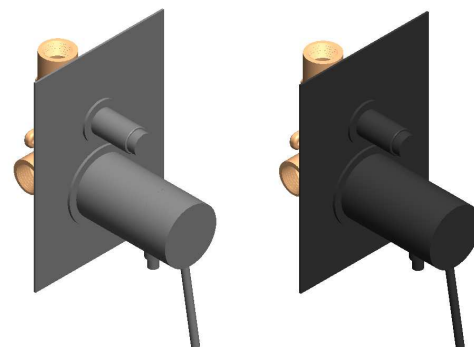
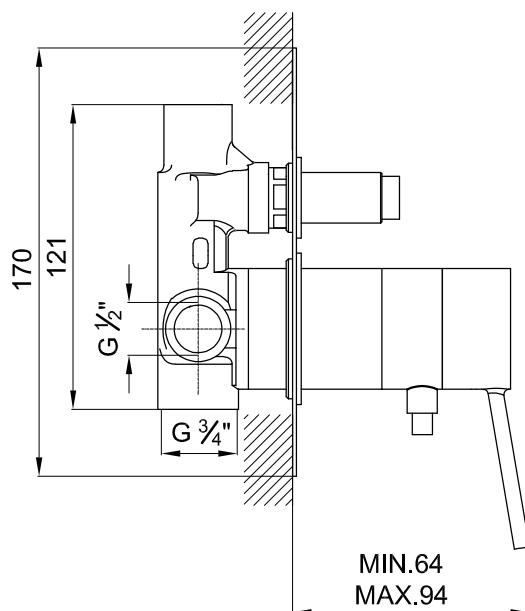
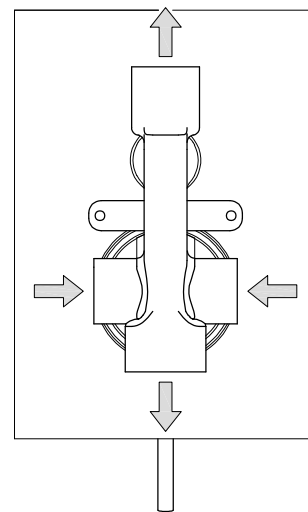
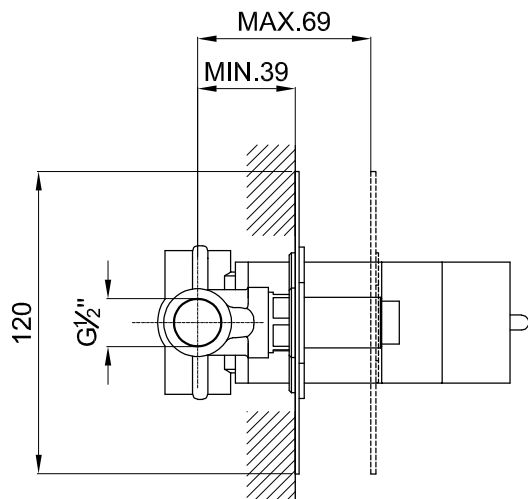

S50005969950706

S50005969971606

COMPONENTES INCLUÍDOS:

PRODUTOS ASSOCIADOS:

- ACESSÓRIOS DE DUCHE: (OPCIONAL, CONSULTAR CATÁLOGO GERAL)
- BASES DE DUCHE: (OPCIONAL, CONSULTAR CATÁLOGO GERAL)
- RESGUARDOS DE DUCHE: (OPCIONAL, CONSULTAR CATÁLOGO GERAL)

Os produtos apresentados seguem especificações técnicas internas da Sanitana SA. As dimensões são meramente indicativas. Para instalação à medida apenas devem ser consideradas as dimensões retiradas da peça a ser aplicada. Reservamos o direito de fazer alterações técnicas que permitam melhorar a funcionalidade dos nossos produtos sem aviso prévio.

Sanitana

FEATURES OF THE MODEL:

- MATERIAL: BRASS (FINISHING: CHROME)
- BRASS (FINISHING: BLACK)
- DEPTH OF INSTALLATION 55 - 85 mm
- WARRANTY: 5 YEARS
- WEIGHT: 2.00 KG

PART:

- DESCRIPTION: BUILT-IN TAP 4 WAYS
- SERIES: UNIC
- VERSION: THERMOSTATIC RECTANGULAR MIRROR PLATE
- REF: S50005969950706 / S50005969971606

SKETCH WITH DIMENSIONS AND CONNECTIONS:

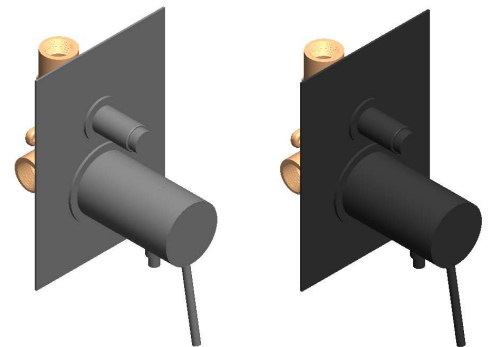
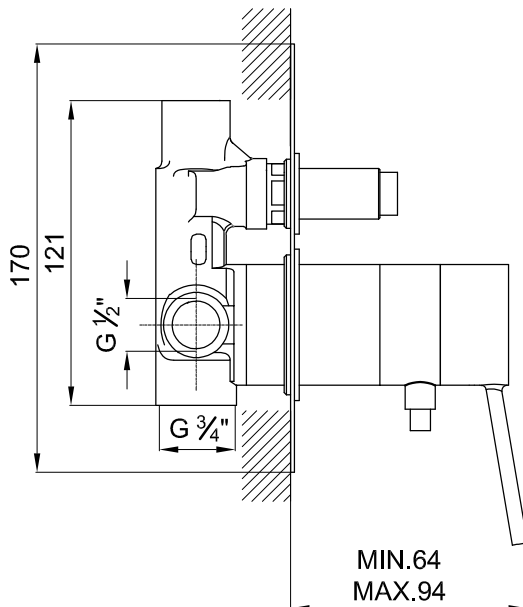
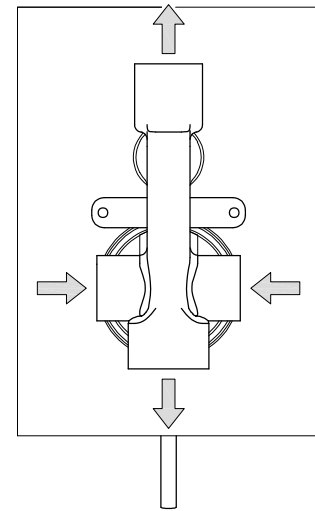
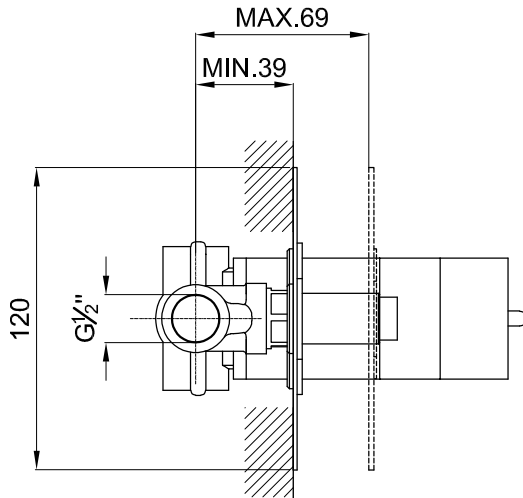

S50005969950706

S50005969971606

INCLUDED COMPONENTS:

RELATED PRODUCTS:

- SHOWER ACCESSORIES: (OPTIONAL, CONSULT GENERAL CATALOG)
- SHOWER TRAYS: (OPTIONAL, CONSULT GENERAL CATALOG)
- SHOWER ENCLOSURES: (OPTIONAL, CONSULT GENERAL CATALOG)

The products presented follow technical specifications by Sanitana SA. Dimensions provided are indicative only. For custom installation, should only be considered the dimensions measured directly on the part to be installed. We reserve the right to make technical changes to improve the functionality of our products without prior notice.